

# End of agreement vehicle condition



Even with careful driving and regular maintenance a vehicle's appearance can deteriorate over time. This is known in the leasing industry as 'fair wear and tear' and this is generally accepted within guidelines regulated by the BVRLA (British Vehicle Rental & Leasing Association).

The following pages will provide you with brief information on what is considered acceptable fair wear and tear for both cars and light commercial vehicles.

You can use the ruler on the opposite page to help with any measurements.

The tables below illustrate indicative costs you may be charged, for any damage to your car or commercial vehicle. Please contact your main dealer for up-to-date prices specific to your vehicle make and model. We strongly advise that you repair any damage to your vehicle before it is returned.

## Indicative cost of repair work to cars

COMPONENT	CONDITION	INDICATIVE COST	NOTES
Bumper	Scratched, dented, loose	£50 - £200	Full bumper repair
Door panel	Scratched, dented	£50 - £300	-
Tyre	Not legal to drive	£80 - £250	Per tyre
Alloy wheel	Gouged, scuffed, cracked	£60 - £600	Per alloy
Windscreen	Excessive chips and cracks	£50 - £700	-
Seat	Tears, burns, stains	£60 - £650	Price per seat
Head / Rear lights	Cracked or broken	£60 - £1000	-
Keys	Missing, damaged	£ MRP plus programming	Per key

## Indicative cost of repair work to light commercial vehicles

COMPONENT	CONDITION	INDICATIVE COST	NOTES
Bumper	Scratched, dented, loose	£50 - £300	Full bumper repair
Door / Side panel	Scratched, dented	£50 - £450	-
Tyre	Not legal to drive	£80 - £200	Per tyre
Road wheel	Gouged, scuffed, cracked	£60 - £600	Per wheel
Windscreen	Excessive chips and cracks	£50 - £600	-
Seat	Tears, burns, stains	£60 - £400	Per seat
Head / Rear lights	Cracked or broken	£60 - £250	-
Keys	Missing, damaged	£ MRP plus programming	Per key

# End of agreement car condition



Deterioration in car condition is not to be confused with damage which occurs as a result of a specific event(s), for example harsh driving, impact, inappropriate stowing of items and negligence. In such event(s) any costs arising from such situations will be recharged.

You can avoid additional costs caused outside the acceptable terms of fair wear and tear by looking after your vehicle carefully. At the end of your agreement another person may want to buy your vehicle; like you, they will most likely expect it to be in excellent condition appropriate to its age and mileage.

Please allow sufficient time prior to the end of your agreement should you need to carry out any repairs before returning your vehicle.

Repairs to windscreens, minor dents and wheel refurbishments can easily be arranged before your vehicle is collected and will avoid unnecessary cost being recharged to you.

It is advisable for any damage to be repaired as soon as possible after it is identified; this is particularly important when the paintwork is damaged and likely to cause further corrosion.

The images below and list on the opposite page show typical examples where recharges may be made. While this will give you a better understanding of what is not considered acceptable when returning your vehicle, you should always refer to the BVRLA guide for more in-depth information.



## IMPORTANT

All repairs must be completed to a satisfactory professional standard. Poor repairs may incur a charge.

Windscreen damage



Bodywork dent



Scratch over 25mm

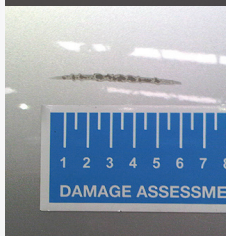

Bonnet paint chip damage

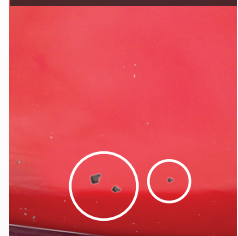

Upholstery damage



Poor paint repair



Wheel damage

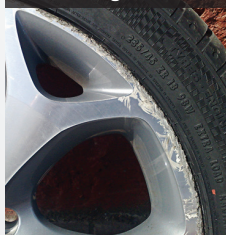

Missing mirror cover



## Typical examples of vehicle recharges



### **Mechanical condition**

Vehicles which cannot be legally driven on a public highway; any engine seizure or damage due to insufficient coolant, oil or broken internal components; a noisy or damaged clutch or gearbox. The engine management system should not be displaying any warning light, e.g. diesel particulate filter (DPF) or oil pressure.

### **Service history**

Missing or unstamped service books; vehicles not serviced to manufacturer's schedule; no current MOT certificate.

### **Scratches**

Scratches that have broken the paint surface and exposed primer or bare metal, exceed 25mm and require the panel to be repainted will be recharged.

### **Windscreen and glass**

Unsecure and leaking, scratching and/or isolated stone chips. Damaged heating element, cracks or holes.

### **Door mirrors**

Missing, cracked or damaged mirror casings.

### **Tyres**

Damage to the sidewall or tread; tyres that do not meet manufacturer's recommendations of type, size and speed rating; uneven wear. Less than 1.6mm depth throughout a continuous band in the centre 3/4 of the tread and around the entire circumference.

### **Wheels and wheel trims**

Any 'spoke' or hub damage to the wheel; scuffing greater than 50mm around the total wheel rim. Damaged or missing spare wheel (or missing emergency tyre inflation kit including

the compressor & canister), jack and other related tools. NB. Partially or fully discharged canisters must be replaced.

### **Unsatisfactory repairs**

Flaking paint, preparation marks, paint contamination, rippled finish, mismatched or off colour paint; poor panel fit or any other evidence of poor repair.

### **Vehicle keys**

Missing keys, including but not limited to, the master, deadlock, slam lock keys (incl. spares), and locking wheel-nut keys. Damaged remote locking system (if applicable) or missing remote controls.

### **Documentation**

Missing vehicle documentation (including the operation manual), audio equipment security codes and any other documents relating to vehicle equipment. Any odometer alterations must be reported. Unauthorised odometer changes are unacceptable.

### **In-car technology**

Damaged or malfunctioning equipment e.g. Bluetooth, sat nav or any other integrated system. CD and media systems with damaged or missing facias and speakers. Any missing original equipment items e.g. parcel shelves, tonneau covers, sat nav discs and SD cards and charging leads.

### **Chips**

Multiple chips; areas of chipping requiring a panel to be repainted and chips which have exposed any bare metal.

### **Livery**

Vehicle returned with livery; damage to paintwork as the result of its removal. This includes glue residue and faded paintwork.

### **Lights and lenses**

Holes or cracks in the glass or plastic covers of lamp units.

### **Bumpers**

Dents or cracks; scuffing or scratches which require the bumper to be repainted.

### **Dents**

Dents on the roof or swage lines; dents more than 10mm, or more than 2 dents per panel; dents where the paint has broken.

### **Soft tops & convertibles**

Tear and rips to the fabric of the roof; cracks and creases in the rear windows.

### **Interiors**

Burns, tears, staining or holes.

### **Underside of vehicle**

Damage to the underside.

### **Mouldings, wheel arch trims**

Broken, cracked or deformed.

### **Rust & corrosion**

There should be no rust or corrosion on any part of the vehicle.

### **Tow bars**

Poor condition (e.g. rust) without working electrical connections. If the tow bar is removed then you are responsible for making good any damage.

---

## **BVRLA fair wear and tear standard**

For full information on acceptable levels of fair wear and tear when returning your vehicle please visit: [www.fairwearandtear.co.uk/ford](http://www.fairwearandtear.co.uk/ford)

---

# End of agreement commercial vehicle condition



Deterioration in commercial vehicle condition is not to be confused with damage which occurs as a result of a specific event(s), for example harsh driving, impact, inappropriate stowing of items and negligence. In such event(s) any costs arising from such situations will be recharged.

You can avoid additional costs caused outside the acceptable terms of 'fair wear and tear' by looking after your commercial vehicle carefully. We recognise that commercial vehicles are working vehicles and, as such, some areas such as working surfaces/loading areas will be subject to a higher level of fair wear and tear. For ease of reference in understanding areas that are subject to, and acceptable as, heavy wear zones please read pages 16 - 17.

Please allow sufficient time prior to the end of your agreement should you need to carry out any repairs before returning your commercial vehicle.

Repairs to windscreens, minor dents and wheel refurbishments can easily be arranged before your vehicle is collected and will avoid unnecessary cost being recharged to you.

It is advisable for any damage to be repaired as soon as possible after it is identified; this is particularly important when the paint work is damaged and likely to cause further corrosion.

The images below and list on the opposite page show typical examples where recharges may be made. This will give you a better understanding of what is not considered acceptable when returning your commercial vehicle.



## IMPORTANT

All repairs must be completed to a satisfactory professional standard. Poor repairs may incur a charge.

Paint removed from base

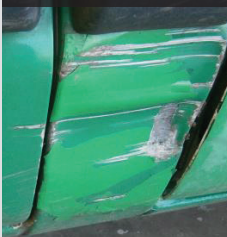

Missing mirror cover

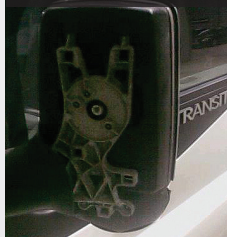

Door damage



Outward dents to panel



Upholstery damage



Left over rubbish

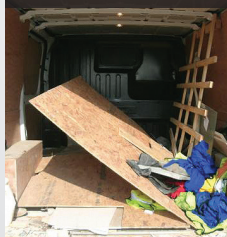

Non-waterproof fittings



Heavy interior wear



## Typical examples of vehicle recharges



### **Mechanical condition**

Vehicles which cannot be legally driven on a public highway, any engine seizure or damage due to insufficient coolant, oil or broken internal components. A noisy or damaged clutch or gearbox. The vehicle's engine management system should not be displaying any warning light, e.g. diesel particulate filter (DPF) or oil pressure.

### **Service history**

Missing or unstamped service books; vehicles not serviced to manufacturer's schedule; no current MOT certificate.

### **Windscreen and glass**

Insecure and leaking, scratching and/or isolated stone chips. Damaged heating element, cracks or holes.

### **Door mirrors**

Missing, cracked or damaged mirror casings.

### **Tyres**

Damage to the sidewall or tread; tyres that do not meet manufacturer's recommendations of type, size and speed rating; uneven wear. Less than 1.6mm depth throughout a continuous band in the centre 3/4 of the tread and around the entire circumference.

### **Wheels and wheel trims**

Any 'spoke' or hub damage to the wheel (steel or alloy). Damaged or missing spare wheel (or missing emergency tyre inflation kit including the compressor & canister), jack and other related tools. NB. Partially or fully discharged canisters must be replaced.

### **Unsatisfactory repairs**

Flaking paint, preparation marks, paint contamination, rippled finish, mismatched or off-colour paint, poor panel fitment or any other evidence of poor repairs.

### **Vehicle Keys**

Missing keys, including but not limited to, the master, deadlock, slam lock keys (incl. spares), and locking wheel-nut keys. Damaged remote locking system (if applicable) or missing remote controls.

### **Decals, labels and sign writing**

Remaining decals, labels, and advertising to the bodywork or glass unless prior agreement has been made by us. Any damage caused by their attachment or removal should be made good. This includes glue residue and faded paintwork.

### **Documentation**

Missing vehicle documentation (including the operation manual). Audio equipment security codes and any other documents relating to vehicle equipment. Any odometer alterations must be reported. Unauthorised odometer changes are unacceptable.

### **In-vehicle technology**

Damaged or malfunctioning equipment e.g. Bluetooth, Sat Nav or any other integrated system. CD and media systems with damaged or missing facias and speakers. Any missing original equipment items e.g. parcel shelves, tonneau covers, sat nav discs and SD cards and charging leads.

### **Lights, lamps and lenses**

Damaged, unapproved or non-operational lights, lamps, reflectors and beacon lights. Holes or cracks are not acceptable.

### **Accessories**

Damaged or missing accessories as provided with the vehicle at the commencement of the lease, such as tool kits, towing pins, roof racks, first aid kits, fire extinguishers etc.

### **Roller shutters**

Excessive scratches to the paintwork on roller shutters. Damage caused by impact or movement of the load. Cracks, holes and other damage.

### **Tail lifts and mounted equipment**

Damaged or distorted platforms and runners. Expired/invalid statutory certificates.

### **Roof racks**

Distortion to the roof, panel or gutter rail.

### **Tow bars**

Poor condition (e.g. rust) without working electrical connections. If the tow bar is removed then you are responsible for making good any damage.

---

## **BVRLA fair wear and tear standard**

For full information on acceptable levels of fair wear and tear when returning your vehicle please visit: [www.fairwearandtear.co.uk/ford](http://www.fairwearandtear.co.uk/ford)

---



# Heavy wear zones

## light commercial vehicles



Commercial vehicles are regarded as 'working' vehicles and their condition at the end of contract must specifically allow for wear and tear appropriate to their operation and use. The images below represent typical goods vehicles with working surfaces (orange zone) and non-working surfaces (blue zone).



---

Car derived vans (CDV), panel vans, boxes and Lutons (GRP and glass fibre).

The rear strip will be in the Blue Zone unless it forms part of the loading area (Orange Zone).

---

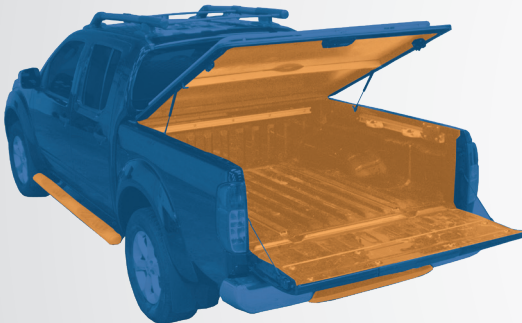

---

Manufacturer built Pick-Up (integrated body at point of manufacture).

---

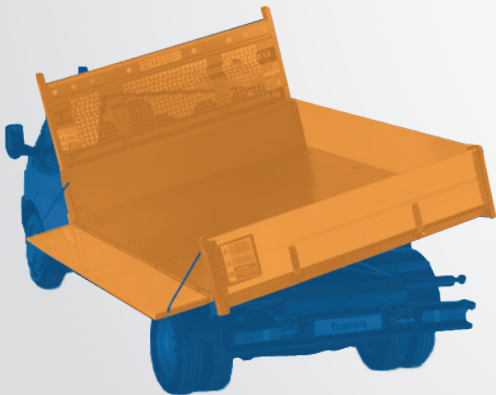

---

Coach Built (body separate from cab), Dropsides, Tippers, Flat Beds and Beaver Tails.

---

## The zones in detail



### Blue zone

Exterior paintwork, body, bumpers and trim are all in this area.

All zones coloured blue are regarded **non working surfaces**

Only light wear and tear is acceptable. Paintwork must be intact and with no deviation to the original shape of the vehicle.

#### Example levels of acceptance:

Chips	Less than 8mm in size	Max of 4 on a panel 8 on a door edge 8 on a forward facing panel
Dents (inward and outward)	Less than 15mm in diameter	Max 2 per panel
Scratches / abrasions	Less than 25mm in length	Max 4 per panel

### Orange zone

Generally, all surfaces and components in contact with load will be in this area.

All zones coloured orange are regarded as **working surfaces**

Heavy wear and tear is acceptable. Paint damage is acceptable on surfaces, however, there must be no deviation to the original shape of the vehicle.

#### Example levels of acceptance:

Chips	Any size is acceptable	No limit
Dents (inward and outward)	Less than 25mm in diameter	No limit
Scratches / abrasions	Any length	No limit

Surface rust is acceptable, however, corrosion that's eaten into the bodywork in any area is not.

## Interior cab and passenger areas

The interior upholstery, facia, headlining and trim must be clean and odourless with no burns, scratches, and tears or staining. Floor coverings and surrounding trims should not be torn or split. Carpets and footwells should not have holes. Wear and soiling through normal use is acceptable. Interior fittings such as seat belts, rear view mirrors, courtesy lights, sun visors,

doors bins etc, must be present, intact and free of damage. All accessories (e.g. first aid kits, fire extinguishers) must be returned intact or replaced with items of similar standard and specification.

For more information please visit:  
[www.fairwearandtear.co.uk/ford](http://www.fairwearandtear.co.uk/ford)